



DR

**Harrison Township Building Department**  
38151 L'Anse Creuse, Harrison Township, MI 48045  
Office: 586-466-1430; Inspection Line: 586-466-1402; Fax: 586-465-2618  
www.harrison-township.org

## **Deck Construction Requirements**

Permits are required if any one of the following items applies:

1. The deck area is covered (roof) in any way.
2. The deck is attached to the house.
3. The deck is 18" or higher.

If the deck is 30" or higher, the following is required:

1. A railing at least 36" high.
2. Vertical balusters must be positioned to acquire a maximum of 4" open space.  
Railing may not form a ladder effect.
3. Proper steps and handrail.

Application drawing requirements as follows:

1. Plot plan indicating setback and dimensions of deck.
2. Signed and sealed survey required for verification.
3. Footing / post-hole plan.
4. Beam and joist layout with dimensions.
5. Railing plan.

## **Township Ordinance**

Section 4.04. Porches/terraces, at-grade patios, step/stairs and decks.

At-grade patios may be constructed within required side and rear yards, but not in a required yard facing upon a street. Unenclosed and uncovered access porches (i.e., one which is not roofed over) or paved terraces may project into a required front or rear yard for a distance not exceeding eight feet. Patio and porches covered or partially covered by permanent construction (awnings excepted) shall not project into any required yard space, but this shall not be interpreted to include or permit fixed canopies or awnings.

Decks may be allowed to project into the required yard, opposite the street, provided that the following conditions are met:

1. The deck does not encroach into any easement.
2. The deck is not located facing any street.
3. The deck conforms with applicable side yard setback requirements.
4. The deck is located not less than ten feet from any detached accessory building. (This separation shall not apply to any attached accessory structure.)
5. The deck elevation shall be no greater than eight inches above the first floor grade elevation of the main structure (except a deck around a pool may match the height of the pool).
6. Any additional structures attached to the deck, such as a gazebo or pool, shall be located at least ten feet from any structure.

# Prescriptive Residential Wood Deck Construction Guide

Based on the 2006 International Residential Code

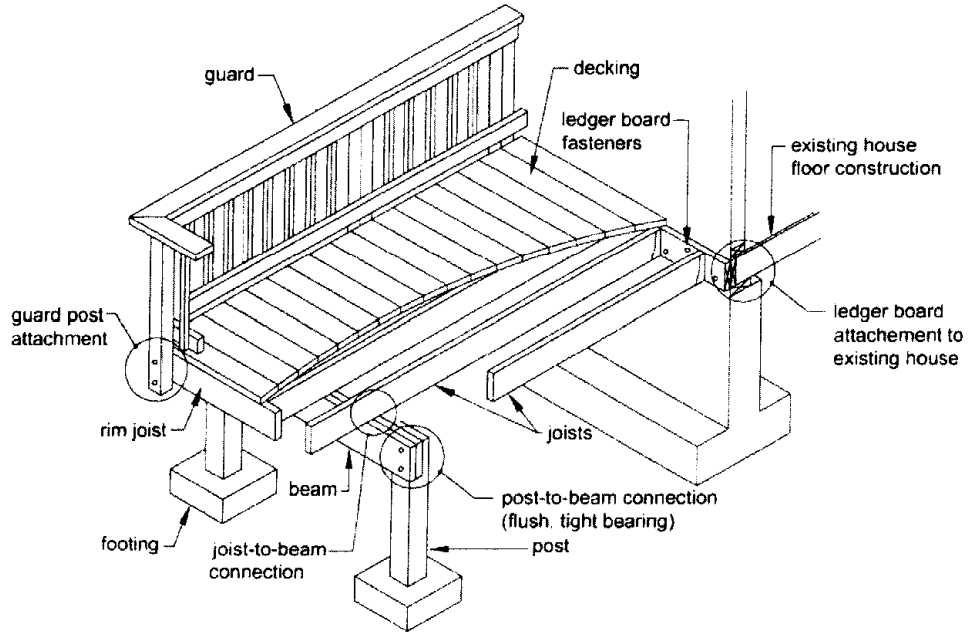

Where applicable, provisions and details contained in this document are based on the *International Residential Code (IRC)* [bracketed text references applicable sections of the *IRC*]. Prescriptive construction methods recommended meet or exceed minimum requirements of the *IRC*. Provisions that are not found in the *IRC* are recommended as good industry practice. Where differences exist between provisions of this document and the *IRC*, provisions of the *IRC* shall apply. This document is not intended to preclude the use of other construction methods or materials. All construction and materials must be approved by the authority having jurisdiction. Every effort has been made to reflect the language and intent of the *IRC*. However, no assurance can be given that designs and construction made in accordance with this document meet the requirements of any particular jurisdiction.

Copyright © 2008 American Forest & Paper Association, Inc.